

PUMA

# PUMA

TRACTORS FROM  
185 – 220 hp



**CASE IH**

**CASE IH**

The aggressive styling of the new Puma is more than a statement, it also incorporates new LED lights to make short work of long nights. This is a driver's tractor with a range of new features with the operator in mind such as:

- Generously dimensioned and illuminated steps
- A hand wash tank for hygiene next to the cab steps
- For the digital user, a new monitor holder with RAM mountings and USB sockets
- Compressed air connections around the Puma for easier cleaning
- Improved arrangement of key implement connections at the rear of the Puma
- A new low mounted windscreen wiper that increases the swept coverage area by 60 % compared to previous Puma models.

#### PUMA MULTICONTROLLER

THE POWERFUL ALLROUNDER FOR MODERN MIXED FARMING AND ARABLE FARMING

- PowerDrive full powershift transmission
- Proven Multicontroller armrest for excellent ease of operation
- Up to 4 (mechanical) or 5 (electrical) rear remote valves
- Headland Management Control II (HMC II) and ISOBUS III
- 540/540E/1,000/1,000E rear PTO
- Hydraulic pumps with up to 150 l/min flowrate
- Actively suspended front axle for superior ride quality and best traction
- AccuTurn Pro - automatic turning at the headland with GPS-based triggers of headland sequences

#### PUMA CVXDRIVE

THE PROVEN SOLUTION FOR FARMS AND CONTRACTORS

- CVXDrive continuously-variable transmission  
4 points of 100 % mechanical efficiency
- APM engine/transmission management for optimal fuel efficiency
- EcoDrive split throttle: whether transporting, baling or mowing - you're always working at the ideal and most fuel-efficient rpm.
- Active hold control - safety on slopes or when leaving the cab
- 40 kph ECO at a fuel efficient 1,500 rpm
- Hydraulic pumps with up to 170 l/min flowrate
- Actively suspended front axle for superior ride quality and best traction
- AccuTurn Pro - automatic turning at the headland with GPS-based triggers of headland sequences



## THE NEW ALPHA ANIMAL IN THE PACK

– our answer to the challenges of the future

ENGINEERED FROM EVERY ANGLE .....	04 – 05
CAB .....	06 – 13
ENGINE, TRANSMISSION, CHASSIS .....	14 – 23
PTO & HYDRAULICS .....	24 – 29

AFS & HMC II .....	30 – 37
SERVICE .....	38 – 43
SUSTAINABILITY .....	44 – 45
SPECIFICATIONS .....	46 – 47

# ENGINEERED FROM EVERY ANGLE

A choice for any requirements

The Case IH Puma has a well-established reputation as a reliable, powerful, economical tractor. It is manufactured in the United Kingdom and is available in a selection of models and performance levels. All Puma tractors have one thing in common: patented engine and exhaust system technology "made by FPT".

## PUMA MULTICONTROLLER

3 Models 185, 200 & 220

With the Case IH Multicontroller armrest and joystick, Puma Multicontroller models put all key operating functions at the driver's right hand. Powershift and powershuttle are operated via Multicontroller buttons, as are the operation of the rear linkage and one of the rear remote valves. Elsewhere on the armrest, features such as engine speed and electrical remote valve operation are at your fingertips, accessed quickly and easily via controls designed to be logically laid-out and easy to differentiate. Multicontroller is the last word in intuitive operation.

## PUMA CVXDRIVE

3 Models 185, 200 & 220

A leader in continuously variable transmissions since their very first development for use in tractors, Case IH today continues to lead the CVT sector with product developments that keep us at the cutting edge of the ultimate in fuel-efficient power transfer. Puma CVXDrive models are as easy to drive as they are economical, with an intuitive operating system that makes them 'jump on and go' machines suited to all types of operator, from casual summer staff to full-time drivers.

## DESIGN

- Attractive bonnet design with large air vents for improved air intake
- Powerful LED lights integrated into the cooler grill – perfectly lighting your working area

## ENGINE

- 6 cylinder 6.7 l FPT turbodiesel with intercooler and wastegate turbocharger
- An eye on the environment: All Puma models meet strict Tier 3 emissions standards
- No external cooled exhaust gas return needed
- Engine power management provides up to 45 hp extra boost
- Reversible eco-fan keeps the radiator grill clean
- 750 hour service interval

## FRONT MOUNT SPACE

- Newly-designed front hydraulics for better reactivity
- Integrated front linkage with optional front linkage management and automatic PTO
- Electronic joystick – quickly switch between rear and front remote valves

## DRIVING COMFORT AND SAFETY

- Actively suspended and braked front axle (option)
- Cab suspension is optional for all Puma models
- Premium leather seat with active suspension available
- Trailer brake system standard for all Puma models
- A new low mounted wiper increases the swept coverage area by 60 % compared to previous models.

## HYDRAULICS

- CCLS hydraulic pumps with flowrates of 120 l/min up to 170 l/min at 210 bar pressure
- Up to 10,463 kg rear lifting capacity and 5,129 kg front hydraulic lifting capacity
- Up to 5 rear electro-hydraulic remote valves
- Up to 3 electro-hydraulic mid mounted remote valves and Power Beyond connections optional

## A CHOICE OF TRANSMISSIONS

- PowerDrive full powershift transmission with automatic gear changes and programmable powershuttle
- CVXDrive continuously-variable transmission from 0 - 40 kph ECO with active hold control
- Electronic parking brake is standard for CVXDrive transmission
- All transmission versions reach 40 kph at low engine speed (40 kph ECO)



	Rated power ECE R120 <sup>1)</sup> @ 2,200 rpm (kW/hp (CV))	Maximum power ECE R120 <sup>1)</sup> with Power Management <sup>2)</sup> @ 1,800 – 1,900 rpm (kW/hp (CV))	Max. pump flow rate Multicontroller / CVXDrive Standard (Optional) (l/min)	Max. lift capacity (kg)	Wheelbase (mm)
Puma 185 Multicontroller / Puma 185 CVXDrive	132 / 180	165 / 224	120 (150) / 150 (170)	10,463	2,884
Puma 200 Multicontroller / Puma 200 CVXDrive	147 / 200	180 / 245	120 (150) / 150 (170)	10,463	2,884
Puma 220 Multicontroller / Puma 220 CVXDrive	162 / 220	191 / 260	120 (150) / 150 (170)	10,463	2,884

<sup>1)</sup> ECE R120 corresponds to ISO 14396 and 97 / 68 / EC <sup>2)</sup> Power Management is only available during hydraulic, mobile PTO and haulage applications



## THE PUMA HABITAT

More than a workplace

If you're looking for a workplace to feel at home in, the Puma CVXDrive and Puma Multicontroller have the cab for you. Extraordinary comfort and excellent user-friendliness let you enjoy even the longest drives. Your work will become an experience with our new features, such as an innovative hands-free phone system, a modern premium steering wheel and a practical RAM mount for mobile devices. Have a seat in your new cab – the future is waiting!

# YOUR COMFORT ALWAYS COMES FIRST

A cab environment like no other

The Puma cab environment is designed for driver's like you. A new monitor bar caters for the digital users with smartphones and tablets.

## THOUGHTFUL DETAILS

Every control element is at your fingertips. No matter which tractor configuration you choose, all models are simple and intuitive to control without hours of poring over the user manual.

## HEATED AND VENTILATED SEAT

The new Puma's optional heated and ventilated red leather seat keeps you cool and comfortable in warm months.



## INTEGRATED COOL BOX

This newly-developed cool box provides enough space for food and drink even for the longest working days. It is located in easy reach of the driver without impeding the view out the front.



## PERFECT VIEW, DAY OR NIGHT

The perfect arrangement of front and side-oriented LED headlights with 40,000 lumens of brightness turn any night into day. Up to 20 LED working lights on the cab roof, A and B pillars provide optimal 360 degree illumination without shadows.

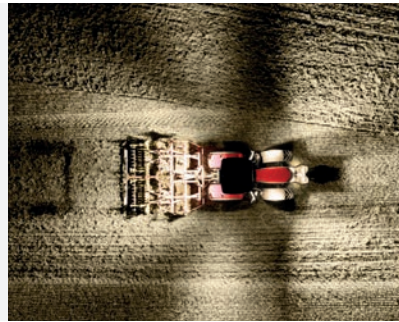

## THE BEST PLACE FOR YOUR MOBILE DEVICES

The RAM monitor mount allows mobile devices such as tablets to be positioned perfectly in the driver's field of view.



## NEW

LOW MOUNTED WIPER INCREASES THE SWEEPED COVERAGE AREA BY 60 % COMPARED TO PREVIOUS MODEL.





AFS PRO 700™ TOUCHSCREEN



OPERATION OF REMOTE VALVES INCLUDING JOYSTICK

MULTICONTROLLER

ICP – INTUITIVE CONTROL PANEL

HYDRAULIC AND REMOTE VALVE SETTINGS

# THE PUMA WORK STATION

Intuitive operation - maximum productivity

**Time is money – and we know how busy you and your employees are.**

The Multicontroller™ armrest, ICP operator's panel and AFS Pro 700™ touchscreen monitor combines all the key tractor functions. The Intuitive Control Panel has the major Puma tractor functions located in a logical layout at the centre of the Multicontroller™ armrest - it's easy to follow and understand for all drivers allowing the operator to quickly get the full potential from the Puma in the field.

## TRUST IS GOOD, CONTROL IS BETTER

The tractor's performance monitor is located on the right A-pillar. It displays all basic settings and tractor information in a clear, comprehensive overview.

Diesel gauge and engine coolant temperature

Warning light display

Gear settings display

Performance monitor

Keypad for selecting/programming the displays



# AFS PRO 700: ONE MONITOR, INFINITE POSSIBILITIES

Look to the future!



## CUSTOMISABLE FOR YOUR NEEDS

The AFS Pro 700 monitor provides an overview of all tractor functions. Choose up to 12 important Puma parameters and store them in this quick access menu to be recalled when you need them.



## KEEPING AN EYE ON WHAT'S IMPORTANT

The monitor can show up to two live videos from several cameras at the rear of the tractor, or the rear of large implements. This makes backing up with implements such as large trailers or balers easier than ever.



## AUTOMATED HEADLAND MANAGEMENT

The Case IH Headland Management Control II system (HMC II) can increase automation at the headland and reduce repetitive tasks, ensuring a consistent workflow. Two processes can be recorded in real time while you work, or by inputting commands on the AFS Pro 700 monitor. Triggers can include time or distance travelled, depending on the settings.



## INTERFACE WITH YOUR TRACTOR

The AFS Pro 700 is the main mode of operating and supervising your Puma: all main functions and status information are

bundled in one display. Menu navigation is intuitive, with important settings accessible within seconds. This lets you get every bit of potential from your machine.

## INTEGRATED AEF CERTIFIED ISOBUS IMPLEMENT CONTROL

ISOBUS is a modern tractor/implement interface allows implement operation on the AFS Pro 700. This can reduce the need for a second display in the cab. Connect via the 9-pin ISOBUS plug at the rear or front of the Puma. Puma Multicontroller and Puma CVXDrive are also compatible with ISOBUS III, which allows the implement to control tractor functions such as the remote valves, PTO, rear linkage and ground speed.



## CLEAR PERFORMANCE MONITORING

You can view all the critical Puma performance and tractor functions such as oil pressure and coolant temperature on the AFS Pro 700. Regular monitoring and easy-to-understand data ensure your Puma is ready for work when you need it. For further analysis, you can choose to transfer your data from the AFS Pro 700 directly to your myCASEIH platform to analyze and improve uptime in the field, without having to record it in a notebook.



## AUTOMATED STEERING AND TURNING

AFS AccuGuide and AFS AccuTurn Pro work together to provide fully automatic steering and headland turning. Combined, they can improve machine uptime in the field and reduce input costs by reducing overlaps. With AFS AccuTurn Pro, you can automate headland processes and integrate HMC II tractor and implement functions into the turning process.





## THE ENGINE OF PROGRESS

Our future-oriented drive train

In the Case IH Puma range, every drive train component has been designed to work together perfectly. An innovative control system lets transmission and diesel engine work as a synchronized team, reaching new dimensions of power, performance and fuel efficiency. See for yourself how our drive train technology results in the highest quality ride and incredible working performance – get ready for the future!





# POWER AND PERFORMANCE

Latest engine technology

## YOUR CONTROL STATION

Puma tractors are built around the latest generation Tier 3-compliant FPT engines, forming the heart of a powertrain to take high-output hard work in its stride. Durable, frugal, reliable and hard-working, these are powerplants which keep on giving in horsepower, torque and dependability. The Puma range now covers a power band from 180 - 220 hp (rated), with all models benefiting from an Engine Power Management boost for PTO and transport work taking those figures from 224 - 260 hp.

## TAKES ON THE HEAVYWEIGHT JOBS – AND THE LIGHTER TASKS TOO

With a high power-to-weight ratio which allows them to be ballasted for heavy draft work yet run light for simpler tasks, these are truly universal tractors. And with 750 hour/12 month service intervals, they require the minimum of regular scheduled care.

That means they spend less time in the yard and more where it matters – in the field, returning the investment you've made in them.

## APM AND ECO DRIVE – SYSTEMS THAT SAVE

All Puma CVXDrive models benefit from Automatic Productivity Management (APM), a system which helps cut fuel consumption by adjusting the engine speed, and CVXDrive transmission to keep PTO speed constant with the Multicontroller™ and travel pedal. The result is the best possible balance of fuel efficiency and power. Engaging ECO Drive enables minimum and maximum engine speeds to be set to match the engine performance to the task in hand, thereby minimising fuel use.

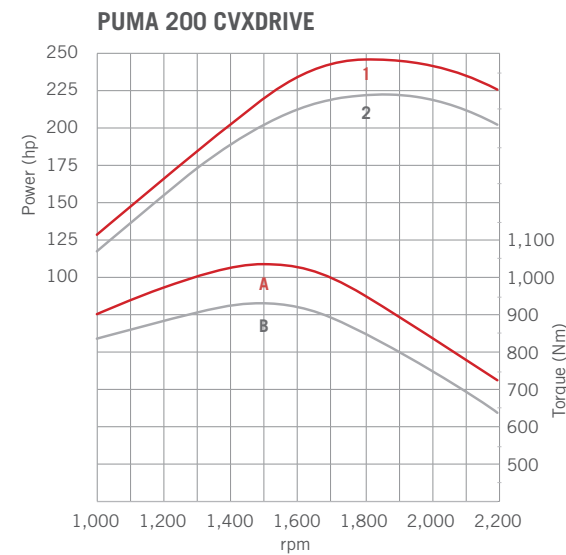

Curves 1 and A with Power Management  
Curves 2 and B without Power Management

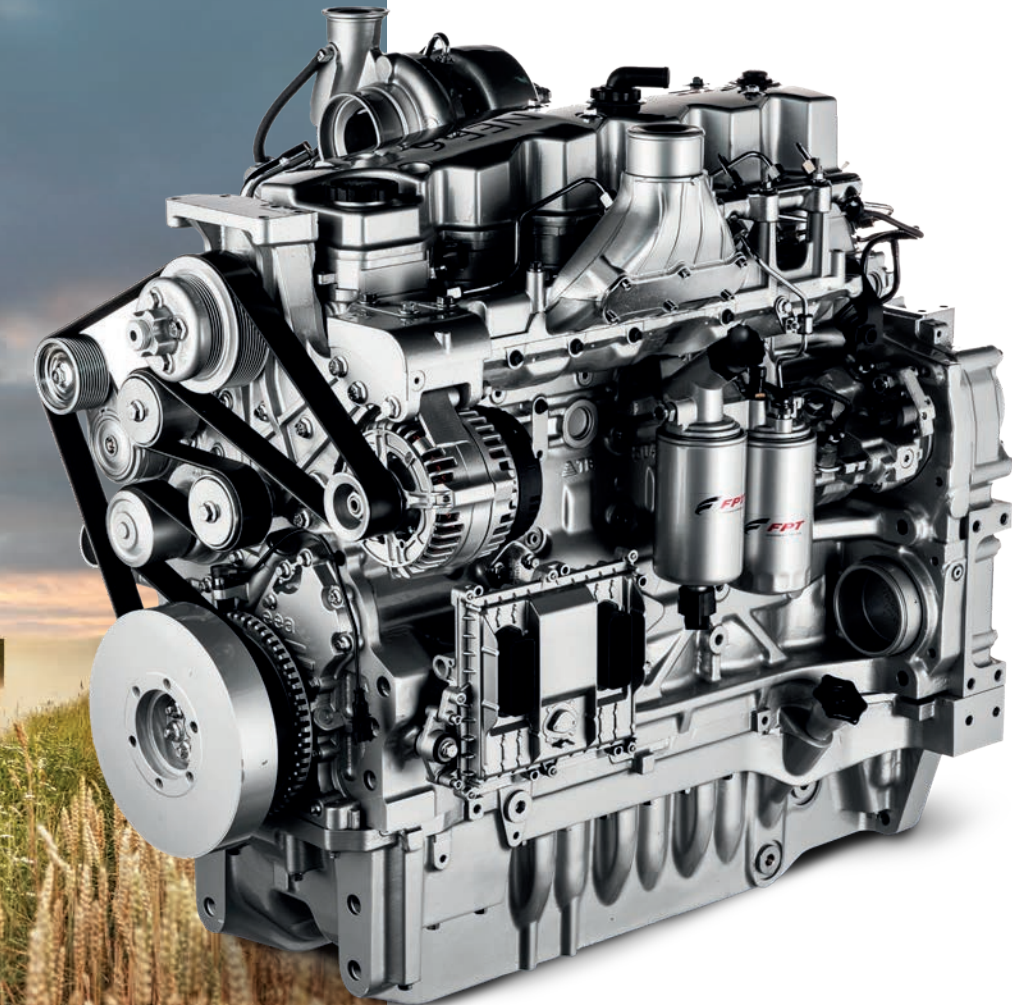

## ADVANTAGES

- Engine Power Management boosts power from 224 - 260 hp
- APM Automatic Productivity Management and ECO Drive helps to cut fuel consumption
- 750 hour/12 month service interval

# ONE COMPONENT WITH MANY POSSIBILITIES

The right transmission for the job

Case IH recognises that no two farm businesses are ever the same and every one demands different things from its tractors. That's never truer than in the transmission department, where what suits one operation may not be right for another. What will the new tractor's main jobs be? How do my employees and I prefer to work? This is why Puma, one of the most versatile tractor ranges in the Case IH line, is offered with two transmission options.

## THE FULL POWERSHIFT

PowerDrive is a 18 speed full powershift transmission (Optional 19th ECO Drive transmission). Designed to provide the optimal number of gears with no clutching or torque interruption in the crucial 2.5 kph to 14 kph working range.

The advantage of Powerdrive is the ease of operation. The Puma Multicontroller puts the transmission control literally in your hand.

A creep speed option is also available for speed sensitive tasks.

## ADVANTAGES

- PowerDrive full powershift transmissions with 18x6 40 kph or 19x6 40 kph (Eco Drive)
- Fully automatic range change
- All transmissions available with creep speed

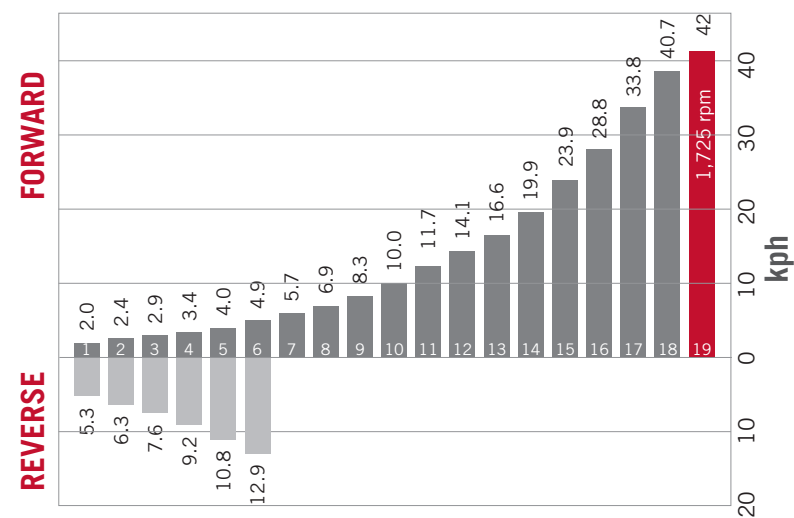

Max. speed 19 x 6 PowerDrive full powershift transmission 40 kph ECO



## CVXDRIVE TRANSMISSION – SEAMLESS ACCELERATION BETWEEN 0-40 KPH

SUMMING PLANETARY TRANSMISSION – COMBINES DRIVE SPEEDS OF THE ENGINE AND HYDROSTAT UNIT FOR ACTIVE HOLD CONTROL

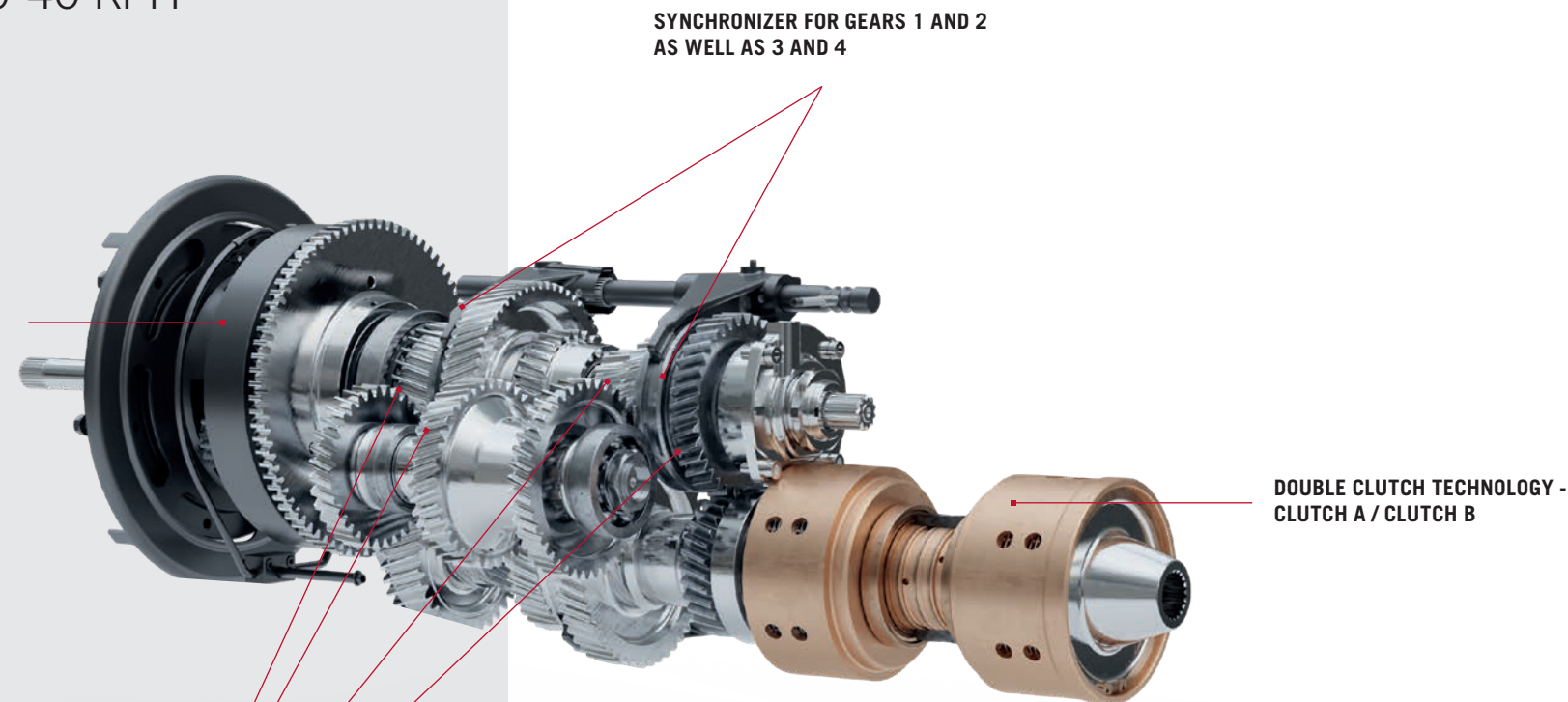

SYNCHRONIZER FOR GEARS 1 AND 2 AS WELL AS 3 AND 4

DOUBLE CLUTCH TECHNOLOGY - CLUTCH A / CLUTCH B

FOUR MECHANICAL DRIVE RANGES WITH AUTOMATIC RANGE CHANGES



**SIMPLE TO OPERATE**

Set the speed – APM takes care of the rest

## EXPERIENCE GIVES YOU THE EDGE

Continuously-variable power

Case IH developed the four-range continuously variable design in the mid 90s - the first tractor manufacturers to do so. Over two decades of experience have let our engineers improve and expand upon this innovation.

### PERFECTLY BALANCED COMPONENTS

The CVXDrive transmission is one of the most efficient in the industry. The four-range hydro-mechanical design can transfer a high proportion of the engine's power to the ground, turning energy into work. There are four points of 100 % mechanical efficiency, three in the key field working speeds and one aimed at transport work.

The sophisticated interplay of the planetary gears, double clutch, four automatically shifting ranges and the hydrostat unit delivers this continuous power from 0 to 40 kph.

### INTELLIGENT EFFICIENCY

The APM engine/transmission management system automatically recognises the selected ground speed and adjusts engine speed and gear ratio to maximize performance. The driver need only move the Multi-controller or step on the foot throttle, APM takes care of the rest. For even greater fuel economy, top speed is achieved at just 1,550 rpm – perfect for transport work. Puma CVXDrive is also a winner when it comes to slow working speeds, with minimum speeds of 0.02 kph.



### A NEW DRIVING EXPERIENCE WITH CUSTOMISABLE TRANSMISSION SETTINGS

Case IH software engineers have enhanced the performance and driveability of the CVXDrive with new CVT control features that deliver smoother and more responsive characteristics, increasing uptime in the field.

Drivers can change the settings easily and quickly via the AFS Pro 700 display.

- Acceleration / deceleration
- Shuttling speed
- Drive pedal behaviour

### INTUITIVE OPERATION HAS MANY ADVANTAGES

With the EcoDrive throttle, the driver can set minimum and maximum engine speed in order to adjust power output to the job at hand. If you are working with a constant speed memory, you can set the right controller to the lowest value that the engine may be reduced to. If the engine RPM drops any lower, APM automatically slows the tractor, saving fuel.

### SAFE AND STRESS-FREE WORK

Active hold control is always a standard feature. It automatically prevents the tractor from rolling on slopes, without needing to activate brakes or clutch. To continue forward, simply push the Multicontroller forward.

# READY FOR ANY TERRAIN

Taking a new path

With an excellent power-to-weight ratio and a high maximum permissible weight, Case IH Puma tractors are strong in the field and on the road.

## A TRACTOR WITH PERFECT TRACTION

Puma's automatic 4WD and differential lock systems can be automatically switched on and off where necessary, to combine minimal wheel slippage with maximum ground protection. The standard Ride Control system minimises pitching movements when transporting heavy mounted implements.

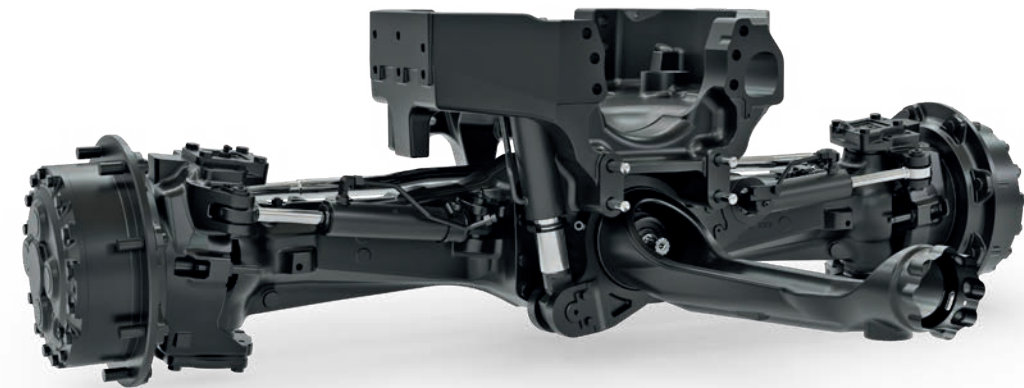

Front axle suspension works in both directions: more comfort, better traction and safety.

## TOUGH, YET GENTLE

Optional front axle suspension increases comfort, improves handling and counteracts tractor pitching caused by heavy rear-mounted implements. A sophisticated damping system provides maximum stability and offers automatic, load-dependent self-leveling. Where front axle suspension is specified, an 'active' system is used in Puma Multicontroller and Puma CVXDrive models, with sensors monitoring various parameters such as acceleration, gear changing, brake actuation, terrain, travel direction change and hitch load. The result is excellent driving stability and comfort.

## CTIS READY

To make the most of the new IF and VF tyre technology available, Case IH Puma models are prepared for CTIS installation. Tapped trumpets allow for the easy installation of a rotary union and for those CTIS working through ISOBUS the tyre pressure and settings can be displayed via the AFS Pro 700 monitor.

## THE PERFECT BALANCE

Puma tractors have a power-to-weight ratio of up to 30 kg/hp, for superb traction with minimal soil disturbance.

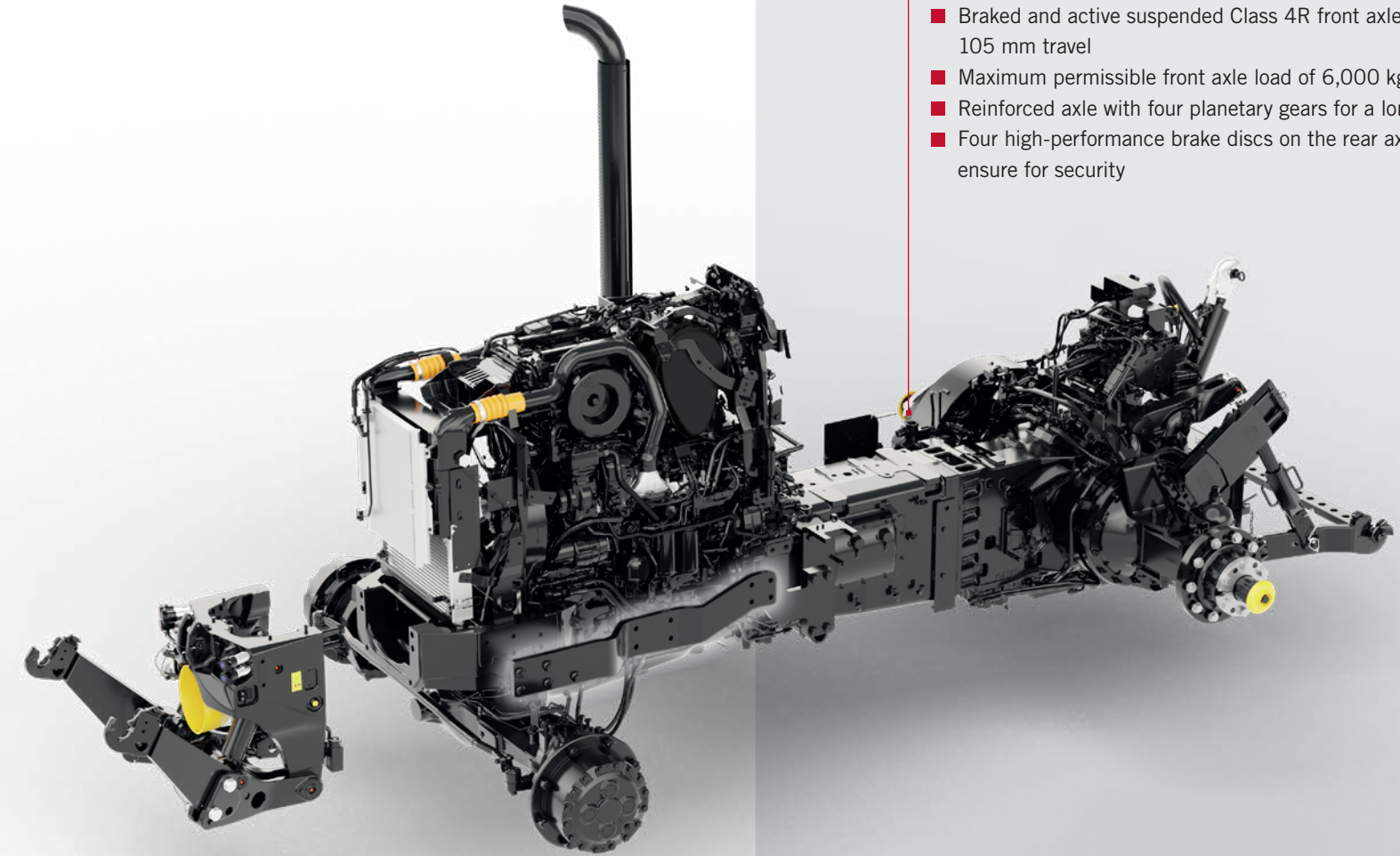

- Stable construction - high payload thanks to increased maximum permissible total weight of 14,000 kg
- Optional engine block side frame increases the stability of the driveline
- Braked and active suspended Class 4R front axle with 105 mm travel
- Maximum permissible front axle load of 6,000 kg
- Reinforced axle with four planetary gears for a long service life
- Four high-performance brake discs on the rear axle ensure for security



## A STRONG ALLROUNDER

Perfectly equipped for any job

Puma's comprehensive, high-performance hydraulics and PTO equipment makes it a true allrounder, able to manage a wide range of implements. When you need to get work done, you want a robust chassis, a tight turning radius and a high permissible total weight (14,000 kg).



# MORE FEATURES, MORE POSSIBILITIES

Ready for work

## VERSATILITY IS KEY

Mowing, tedding, baling and more – the rear PTO has a lot of jobs to do, and Case IH has practical solutions for all of them. Puma tractors work with all common rpm speeds and even come equipped with the 4-speed rear PTO (540/540E/1,000/1,000E) as an option. PTO speed is easily pre-selected via a potentiometer.

## WE HELP YOU SAVE

The ECO PTOs are designed especially to match engine characteristics, so that 540 ECO or 1,000 ECO speeds are achieved at just 1,590 rpm engine speed. This not only saves fuel on lighter work, but also keeps the noise level down.

## UNSURPASSED

Numerous additional functions ensure optimal operation: soft start engagement gradually increases torque on the driveline to prevent excessive start resistance. This reduces wear on your implements, extending their service lives. A hydraulic brake also ensures that speed is reduced immediately once the PTO is switched off. The PTO management system (Puma Multicontroller and CVXDrive) switches the rear PTO off when the hitch has reached a predefined height, and back on again after

turning, all fully-automatically. This prevents the PTO and implement from continuing to run at a bad angle to each other.

## THE RIGHT SPEED AT THE PUSH OF A BUTTON

When using the PTO, the constant speed memory can be activated. AFS Pro 700 lets you preset a suitable engine speed for the implement, which is activated by pressing a button or by the HMC II. This saves valuable time and fuel.

## ADVANTAGES

- Up to four PTO speeds at the rear for all Puma models are available
- ECO PTO speeds for better fuel economy (540E and 1,000E at just 1,590 engine rpm)
- Front PTO with 1,000 rpm and optional front linkage management

- Heavy-duty PTO clutch with soft start function
- Integrated PTO brake
- PTO with four speeds and two Economy PTO speeds (540/540E/1,000/1,000E)
- Three different PTO shafts possible

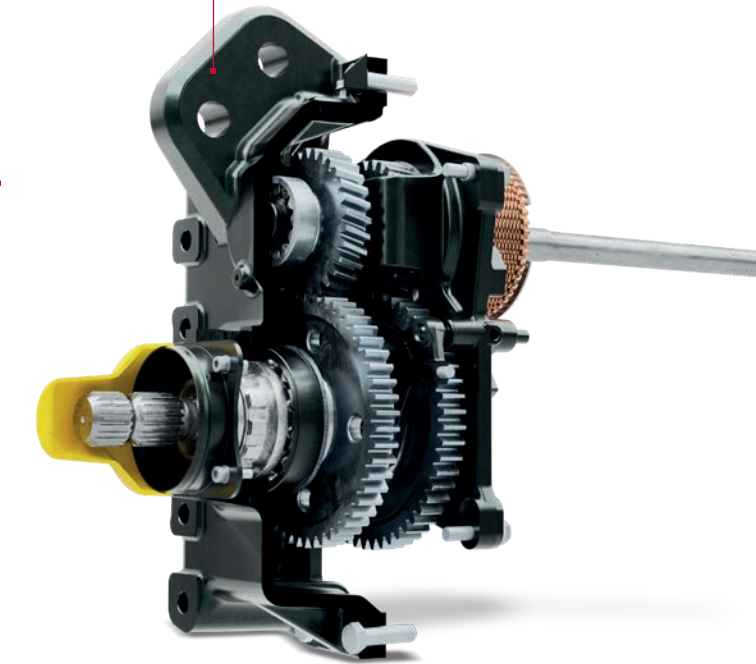

# CONNECT ALL KIND OF IMPLEMENTS TO YOUR TRACTOR

Simple solutions even for the heaviest implements

A tractor's hydraulic capabilities play a large part in defining its uses. Case IH Puma tractors are fitted with high-performance hydraulic pumps, hitches and remote valves, allowing you to use large implements.

## MOVE IT ALL

Puma's advanced hydraulic system leaves nothing to be desired: pump flowrates of up to 170 l/min are available, with up to 8 electrical remote valves and a rear hitch lift capacity of 10.5 t.

## PERFECTLY MATCHED

Load sensing Power Beyond connections are available so you can efficiently operate special machines requiring large flowrates. If electrical remote valves are equipped, the electronic joystick is a huge advantage as a controller, especially when using a front loader.

## EVERYTHING IN HAND

Puma and Puma Multicontroller are also available with a wide range of hydraulic equipment to suit your unique needs. Choose electric or mechanical remote valves.

## FRONT END TAKES THE LEAD

The Puma's front linkage can lift up to 5,129 kg and can be fitted in combination with a front PTO and/or front linkage management. This opens up even more practical possibilities.

## CUSTOMIZED SETTINGS

If your Puma is equipped with HMC II, any remote valve can be assigned to the Multicontroller. Keep all hydraulic functions exactly where you want them. With flowrate control, you can adjust the flowrate of hydraulic oil to perfectly match the implement – either from the AFS Pro 700 monitor or via the dial encoder under the armrest cover. Timing and prioritizing the remote valves is another standard function.

## ADVANTAGES

- Maximum rear lift capacity of up to 10,463 kg
- 5,129 kg maximum front lift capacity
- 4 mechanical or 5 electrical remote valves
- Electric joystick control
- Up to 3 electrical mid-mounted remote valves
- Colour coded remotes and control switches



Pressure and flowrate-controlled hydraulic block with up to 5 electro-hydraulic remotes and Power Beyond connections



At-a-glance overview of flowrate and timer settings on the AFS Pro 700™ monitor.



■ A new more ergonomic arrangement of implement connection features makes it easier and quicker to hitch up.

■ Top links by their nature are heavy - Case IH have refined the latch and stowage to make it easier work with.

- Cat. II-III quick adjust
- Cat II-III lower link with automatic stabilisers
- Optional hydraulic lifting struts
- Exterior buttons for hitch, additional remotes, and PTO on/off



## SMART, COST-EFFICIENT AND ECO-FRIENDLY

Case IH Advanced Farming Systems (AFS™)

Since its founding, Case IH has been setting milestones in the industry in terms of engines, transmissions and intuitive operating concepts. We look at existing potentials, develop suitable solutions, and implement them. We aren't satisfied until our innovations have simplified and improved your daily work.

Our AFS Advanced Farming Systems have set a trend for smart solutions in precision farming. AFS connects the tractor's and implement's control systems through full ISOBUS compatibility and HMC II headland management. Take advantage of your Puma's industry-leading technology for more performance, productivity and flexibility.

Slip 3 %  
Engine Power 91 %

Ground Speed 6.0 km/h  
Engine Power 54 %

Coverage Area 26.3 ha  
Fuel Rate 89.3 l/h





# CASE IH AFS™

Take advantage of maximum precision – day in and day out

**Case IH Advanced Farming Systems (AFS™) have been at the forefront of precision farming for more than a decade. Case IH AFS tools include everything you need to achieve repeatable accuracy down to 1.5cm, reduce overlaps, cut operating costs and maximise your profitability.**

## A FULLY-INTEGRATED SOLUTION

Your Puma CVXDrive can be made “AFS™ AccuGuide Ready” on the assembly line with installation of the AFS Pro 700™ touchscreen and steering position sensors. You may also choose to retrofit a fully-automatic

GPS/Glonass steering assistance system. Using the signal from a local RTK+ station gives you track-to-track accuracy of 1.5cm. The RTK system bridges breaks in reception or signal drop-outs of up to 20 minutes with the xFill app, keeping you right on track even where there is shadowing due to buildings, etc. In addition, some European markets will receive signals from Galileo satellites, in addition to GPS and GLONASS, enhancing the precision of your farm planning even more.

With the optional Case IH AFS Connect™ telematics system, your Puma CVXDrive can be pinpointed in real

time from the comfort of your office. An analysis of the performance data can help you optimise logistics and efficiency coupled with lower fuel consumption.

## OUR GOAL: OPTIMAL COVERAGE, MINIMAL FAILURE RISK

Integration of the Galileo satellite network provides a substantial boost to network coverage for our customers in Europe and further reduces the signal failure risk. If the signal is lost, the excellent coverage ensures that it is quickly restored.



Automated turning process with AFS AccuTurn Pro



xFill bridges RTK+ signal losses of up to 20 minutes

## ADVANTAGES

- Range of signal accuracies available
- Receivers use both GPS and GLONASS signals
- Low cost RTX signal solution
- Optional high accuracy RTK+ signal with accuracy levels close to 1.5 cm
- Integrated automatic AccuGuide guidance
- xFill bridges RTK signal gaps of up to 20 minutes
- AFS Connect telematics provides machine tracking and performance data

# AFS CONNECT

Manage your farm, fleet and data remotely



AFS Connect lets you remotely monitor and manage your farm, fleet and data, allowing you to optimise your performance, productivity and flexibility. Efficiently visualise your equipment with little to no idle time. With all the information at your fingertips, you can successfully manage your operations anytime, anywhere!

## USER-FRIENDLY INTERFACE

- New, intuitive and redesigned interface with all information at your disposal
- Ergonomic platform divided into 3 sections: fleet, farm & data

## TIME-SAVING MANAGEMENT

- Visualisation of data from multiple machines in one field
- Manage your activity & transfer data from your office to machines and vice versa

## MAXIMUM PRODUCTIVITY-ENHANCING DECISION MAKING

- Notifications & visualisation of critical operating parameters
- Connect and share securely with Application Programming Interface (API)

Go anywhere, see everything

## RECEIVE UPDATES ON YOUR DAILY OPERATIONS

- See, share and manage data on the go, in real time, from any device
- View updated machine telematic data and fault codes remotely

## THE ULTIMATE SOLUTION FOR WHEN YOU'RE ON THE MOVE.

- Live vehicle map lets you find machines' locations and get driving directions
- Share vehicle info, location and directions with various apps (e.g. WhatsApp) on your phone

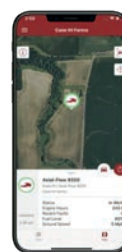

## YOUR ALL-NEW DESTINATION FOR CASE IH PRODUCT SUPPORT

MYCASEIH is a new free cloud-based platform which gives you a single place to log in for access to everything related to your Case IH farm equipment. Find an overview of all your machine and equipment, manage your users and access a support knowledge section with operator manuals, support documents, parts catalogues and more. The platform is available on all devices: smartphone (Apple & Android), tablet and desktop.

VISIT US AT [MY.CASEIH.COM](http://MY.CASEIH.COM)



## FARM MANAGEMENT

### GET MORE DONE EACH DAY

Optimise your time by easily organizing your fields, applications and agronomic data

## MANAGE YOUR COMPANY

Managing your fields and your data can be time-consuming. AFS Connect optimises your time by easily organising your fields, applications and agronomic data.

With a wealth of information at your fingertips, you can boost your operation's performance.

- **Data visualisation:** access agronomic data in near real-time for all your seeding, application and yield activities. Included: topographic, weather, equipment, or prescriptions information.
- **Reporting:** capture all of your critical farming information on the go or directly from your equipment. Plan upcoming activities, manage logistics, share data with your trusted advisors and make informed decisions
- **Usability:** Keeping track of everything going on in your operation has never been easier. Whether you're on the road, in the field or at the office, the intuitive user interface keeps you informed.



## FLEET MANAGEMENT

### TRACK, MONITOR & MANAGE YOUR ENTIRE FLEET

Efficiently track your equipment's location & view machine parameters in real time

## MANAGE YOUR PRODUCTIVITY

When all your equipment operates efficiently with little to no idle time, you have the peace of mind that comes with working smarter and knowing that you're doing all you can to make the most of each growing season.

- **Fleet overview:** access key information with detailed performance values for each machine by vehicle type. The map overview allows visualisation of connected equipment to more efficiently execute infield operations and coordinate the fleet.
- **Vehicle details page:** access recent machine operations and get a 7 day report of the vehicle status by hours and fuel usage.
- **Fault history and notifications:** view and filter the faults shown to the operator on the in-cab displays. Configure and setup notifications such as vehicle speeds, oil temperature, engine load or fuel level and receive them via web or via text messages.

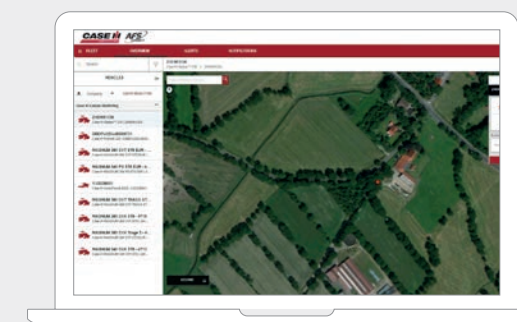

## DATA MANAGEMENT

### CONNECT AND SHARE DATA

Securely share your farm data with trusted partners, anytime, anywhere

## MANAGE YOUR DATA EXCHANGE

Seamlessly manage, share and move data – all while ensuring you stay in complete control with your preferred trusted business partners.

- **Secure data sharing:** Securely share selected data with trusted partners while keeping complete control of who can access each piece of generated data.
- **Third-party partners:** wirelessly transfer two-way data between AFS Connect and trusted third-party suppliers (AgDNA, Cropio, Farmers Edge™, Trimble® Ag Software, Climate Field View...) to make the most of agronomic data and drive daily management decisions

**Solutions for mixed fleets:** Case IH customers benefit from a comprehensive solution for sharing data thanks to two recent partnerships:

- DataConnect is a new cloud-to-cloud interface, in partnership with CLAAS, 365FarmNet, John Deere and New Holland. Mixed-brand fleets owners can look forward to easier data exchange and management without compatibility issues.

- With the universal data transfer hub Agrirouter (including many other tractor and implement brands like AGCO, SDF, Krone, Pöttinger, Lemken, Kuhn, etc., list available at <https://my-agrirouter.com/en/agrirouter/brands/>) to help ensure compatibility of tractor and implement data management systems.

# AUTOMATED OPERATING SEQUENCES FOR INCREASED PRODUCTIVITY

Work productively, accurately, and in comfort with the headland management system, AccuTurn plus, and integrated ISOBUS compatibility

The monitor integrated into the operator's seat armrest gives the operator full control over all the tractor's automatic functions and connecting the reversing camera.

## HMC II

All Puma models feature Headland Management Control II, which is designed to assist the driver when turning at the headland. Each step can be programmed either by time or distance travelled. In addition, triggers for various other automated functions can be set, such as lowering the engine speed after lifting the implement. A headland sequence can be recorded while driving or programmed on the stand. The sequence can be played back manually or automatically via the Multicontroller, the ICP control panel in the armrest, or the AFS Pro 700 monitor.

## ISOBUS III FOR BEST EFFICIENCY

In addition to the ISOBUS I and II standards, which suggest implement settings via the AFS Pro 700 monitor (Class I) and control implements (Class II), the Puma CVXDrive also offers ISOBUS class III. With ISOBUS III, the implement automatically controls aspects of the Puma CVXDrive. The tractor will automatically adjust forward speed, steering (option), hitch position and PTO speed, as well as operating remote valves depending on the implement's needs. The result is perfect cooperation and improved efficiency of the implement and tractor.

## AUTOMATED TURNING PROCESS

Our brand new AFS AccuTurn Pro technology combines headland management and headland steering processes. Turning radius, speed, and implement control when turning on headlands are automated and optimized, resulting in increased efficiency and improved comfort.



ISOBUS functions can be configured onto existing controllers such as the Multicontroller, joystick and control levers.

**PRESS CONTROLLER**  
Large baler loading control algorithm (software)

ISOBUS CLASS III

**TRACTOR CONTROLLER**  
Speed adjustments made based on relevant signals from the baler

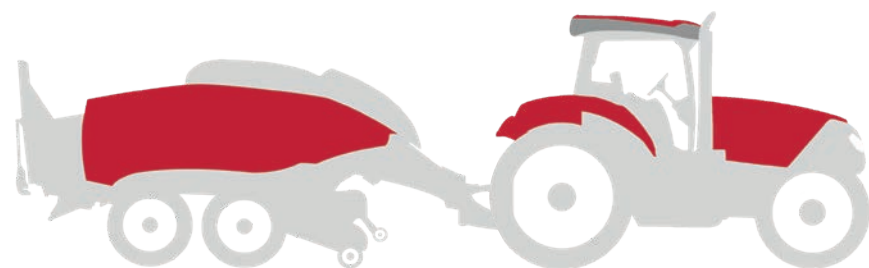



# BE A FARMER

We take care of the rest

At Case IH, we see it as our responsibility to be at the customer's side anytime he or she has a question. Our intensive after sales support includes a comprehensive service package and customer service programme, which has the answer to any question. A strong local network allows us to be close to you when you need us. Our services include tech support to financing, AFS questions, service checks and even organization and provision of the right spare parts. That's what modern service is all about.



# UPTIME IS ALWAYS ON OUR MIND

Because it's always on yours

## **DAY-TO-DAY SERVICE HAS NEVER BEEN EASIER**

We know time is critical in this business, and the less you need to spend on servicing the better. Daily maintenance on Puma tractors is straightforward, easy and quick in order to reduce costs and machine downtimes.

## **750-HOUR OIL CHANGE INTERVALS**

Industry-leading oil service change intervals help keep you in the field longer.

## **EASY ACCESS TO THE FUEL FILTER**

The filter is located on the lower right-hand side of the engine compartment to improve serviceability and access.

## **LARGE FUEL TANK**

A large fuel tank of 390 litres guarantees long working days without refilling.

# SERVICE TEAM

Be a farmer. We take care of the rest

The Case IH **SERVICETEAM**, a strong dealer network backed up by local Case IH market teams, industry-leading Case IH support tools, modern training methods, best-in-class spare parts support and logistics performance: These provide Case IH customers with excellent all-encompassing after-sales service, keeping you farming!

## GENUINEPARTS WE KEEP YOUR EQUIPMENT RUNNING.

Your local Case IH dealer and our dedicated 24/7 parts call centre technicians and their logistics colleagues are all part of the Case IH ServiceTeam network. They're highly trained to give you expert advice and solve problems, ensuring the correct, genuine Case IH parts are located and dispatched right away, reaching you next day or sooner to keep your machine in top condition.

## MAXSERVICE AROUND THE CLOCK. AROUND THE COUNTRY.

When you're working around the clock, MaxService ensures you're never alone. It's a dedicated helpline that connects you to the Case IH ServiceTeam 24/7. Call technicians at your local dealer are ready to assist with technical advice, software solutions and genuine parts ordering. At peak season, we can keep you farming with breakdown assistance.

## SAFEGUARD SAFEGUARD THREE-YEAR WARRANTY

The best things come in threes: Our extremely high quality standards and continual improvements to our products have allowed us to offer a 3-year factory warranty. The warranty covers all necessary repairs in years 2 and 3 to the extent of the base warranty. Labour and Case IH original parts are covered for every warranty repair without any unexpected cost to you. Terms and conditions apply, call your local Case IH dealer for details!



## OPTIMAL FINANCING SOLUTION FOR EVERY INVESTMENT.

CNH Industrial Capital is the financing company for Case IH. Our employees are financial experts and have many years of experience in agriculture. We do not only know about Case IH products and the market – we also understand the individual requirements of your operations. Therefore we are always able to offer you a financial solution for your new investments that is tailored specifically to your operational requirements. Our most important goal is improving the profitability of your investments!

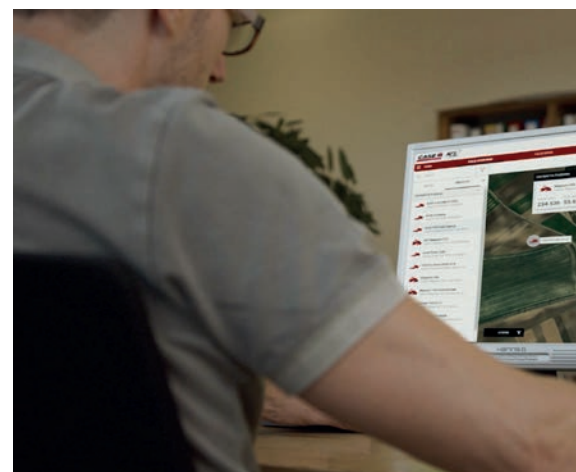

# SUSTAINABILITY

It's a part of everything we do



REDUCE THE CONSUMPTION OF RESOURCES BY MOVING FROM FOSSIL FUELS TO A **RENEWABLE ENERGY SYSTEM**



INCREASE AGRICULTURAL PRODUCTIVITY TO **IMPROVE FOOD** AVAILABILITY



REDUCE **ENVIRONMENTAL IMPACT** AND OPTIMIZE **ENERGY CONSUMPTION** IN ALL COMPANY PROCESSES



INCREASE OPPORTUNITIES FOR EXCHANGING **IDEAS** AND **GOOD PRACTICES** WITH ALL **STAKEHOLDERS**

Case IH is part of CNH Industrial, one of the world's largest capital goods companies. It has a firm focus on its environmental responsibilities, and has been a nine-time leader in the Dow Jones Sustainability Index.

#### WITHIN THE CNH INDUSTRIAL GROUP:

- 91 % of waste is recovered
- 27.5 % of water used is recycled
- 56 % of electricity used is from renewable sources.

Being a global leader in capital goods carries great responsibilities, which means that we must be accountable for every global activity we perform. Our responsibility does not stop at the factory gate, and we have made great efforts to be proactive when it comes to the broader global issues surrounding sustainability. Over the years, our work in research and

development has been geared towards ensuring that our products continue to achieve increasingly high standards in terms of safety and eco-compatibility. Rather than limiting customers to a choice between low operating costs and eco-efficiency, our strategy is to offer products that deliver both.

By providing innovative products and solutions that abide by environmentally responsible operating practices, Case IH is doing its part to address global issues such as climate change. Today's companies face complex and interconnected challenges that demand an ever-evolving approach to sustainability, a scenario that Case IH believes is an important driver in creating long-term value for all its stakeholders, which is a core objective of the brand.

At Case IH, our engineers are focused on producing machines that not only work on the land, but work with it too.

#### THE SUSTAINABILITY GROWTH DRIVERS ARE:

- Necessity of feeding an increasing population
- Importance of soil protection for future generations
- Growing sustainable farming solutions
- Increasing public awareness
- Fostering public engagement

# CNH

Breaking  
New Ground

Innovation Sustainability Productivity

MODELS	PUMA 185 MULTICONTROLLER	PUMA 200 MULTICONTROLLER	PUMA 220 MULTICONTROLLER	PUMA 185 CVXDRIVE	PUMA 200 CVXDRIVE	PUMA 220 CVXDRIVE
<b>ENGINE</b>						
Engine Type / Emission Level	Case IH FPT / Stage 3A					
Number of Cylinders / Fuel Type	6 / Common Rail Diesel Engine					
Engine Aspiration	Turbocharged & Intercooled					
Valves / Displacement (litres)	24 / 6.7					
Bore x Stroke (mm)	104 x 132					
Maximum power ECE R120 <sup>31</sup> Power Management <sup>2)</sup> [kW/hp(CV)]	165 / 224	180 / 245	191 / 260	165 / 224	180 / 245	191 / 260
Maximum power ECE R120 <sup>31</sup> [kW/hp(CV)]	147 / 200	162 / 220	176 / 239	147 / 200	162 / 220	176 / 239
... at engine speed [rpm]	1,800			1,800		
Rated power ECE R120 <sup>31</sup> Power Management <sup>2)</sup> [kW/hp(CV)]	161 / 218	176 / 239	187 / 254	161 / 218	176 / 239	187 / 254
Rated power ECE R120 <sup>31</sup> [kW/hp(CV)]	132 / 180	147 / 200	162 / 220	132 / 180	147 / 200	162 / 220
... at engine speed [rpm]	2,200			2,200		
Maximum torque Power Management <sup>2)</sup> [Nm @ 1,500 rpm]	940	1,035	1,100	940	1,035	1,100
Maximum torque [Nm @ 1,500 rpm]	840	930	1,000	840	930	1,000
Torque Rise Standard [%]	44%	45%	44%	44%	45%	44%
Fuel Tank (litres)		460			450	
<b>TRANSMISSION</b>						
CVXDrive continuously variable transmission 40 kph ECO		-			•	
PowerDrive 18x6 full powershift 40 kph		•			-	
PowerDrive 19x6 full powershift 40 kph ECODrive @ reduced rpm		◦			-	
Powershuttle		•			•	
Creeper			◦			
Rear axle diff-lock type	Multi disc wet plate with management system					
Service brake	Hydraulically operated multiple wet disc brake, self adjusting					
<b>POWER TAKE OFF</b>						
Type	Shiftable with progressive electro-hydraulic engagement. Auto-PTO optional					
Speeds Standard (Option)	540 / 540E / 1,000 / 1,000E (540E / 1,000 or 1,000 / 1,000E)					
... at engine speeds Standard (Option) [rpm]	1,931 / 1,598 / 1,912 / 1,583 (1,569 / 1,893 or 1,893 / 1,700)					
Shaft type Standard (Option)	1 3/8" 21 splines (1 3/8" 6 splines or 1 3/4" 20 splines)					
<b>FRONT PTO AND FRONT HITCH</b>						
Front PTO 1,000 speed @ engine rpm	1,833					
Front hitch max. lift capacity [kg]	5,129					
<b>FOUR-WHEEL DRIVE AND STEERING (DRIVELINE)</b>						
Type	Electro-hydraulic with management system, differential lock as standard					
Active front axle suspension	◦					
Min. turning radius <sup>3)</sup> track setting 1,829 mm [m]	6.1					
<b>HYDRAULIC SYSTEM</b>						
System type	Variable displacement, pressure flow compensated pump					
Max. pump flow rate Standard (Option) / System pressure	120 l/min (150 l/min) / 210 bar					
Control type	Electronic Hitch Control (EHC) with cushion ride control					
Max. lift capacity [kg]	10,463					
OECD lift capacity through range @ 610 mm [kg]	7,280					
Max. number of rear remote valves	4 mechanical or 5 electrical					
Max. number of mid mount valves with electronic joystick	3 electrical					
Remote valve timer control	1 - 60 seconds on all models					
Category type	Cat II-III quick adjust					
Slip control	◦					
<b>STANDARD TYRES <sup>4)</sup></b>						
Front	600/65 R28					
Rear	650/65 R42					

MODELS	PUMA 185 MULTICONTROLLER	PUMA 200 MULTICONTROLLER	PUMA 220 MULTICONTROLLER	PUMA 185 CVXDRIVE	PUMA 200 CVXDRIVE	PUMA 220 CVXDRIVE
<b>WEIGHT / DIMENSIONS <sup>3)</sup></b>						
Approximate shipping weight standard / suspended front axle [kg]				8,500 / 9,550		8,800 / 9,550
Permissible total weight [kg]				13,650		14,000
A: Max. length with front and rear lower links down standard / suspended front axle [mm]				5,398 / 5,517		5,398 / 5,517
B: Total height [mm]				3,314		3,314
C: Minimum width across rear fenders (narrow / wide type fender) [mm]				2,550 / 2,750		
D: Wheel base standard / suspended front axle [mm]				2,884 / 2,884		
E: Height at centre of rear axle, highest point cab [mm]				2,339		
F: Track setting front / rear [mm]				1,538-2,260 / 1,530-2,230		



PUMA  
MULTICONTROLLER

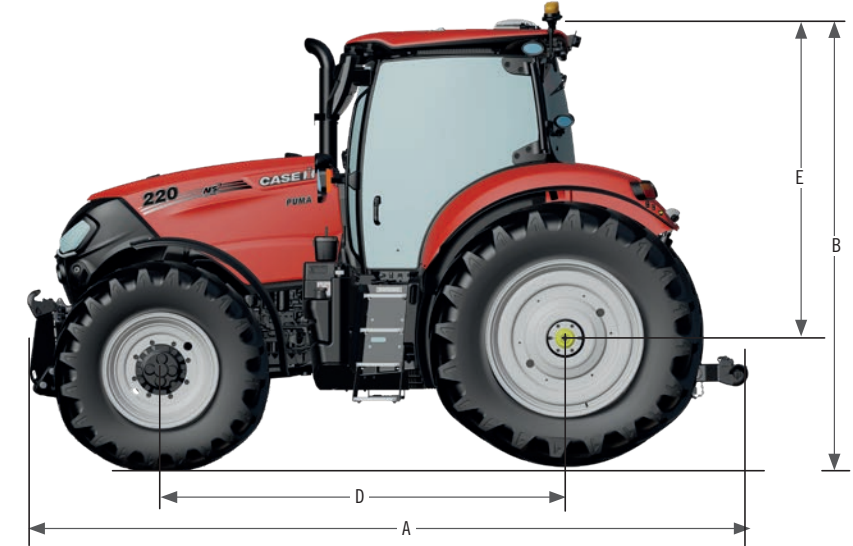

PUMA  
CVXDRIVE

- Standard Equipment
- Optional Equipment
- Not available

<sup>31</sup> ECE R120 correspond to ISO 14396 and 97 / 68 / EC

<sup>2)</sup> Power Management is only available during hydraulic, mobile PTO and haulage applications

<sup>3)</sup> With standard tyres

<sup>4)</sup> Other tyres on request





     
caseih.com

 Free phone: 00 800 22 73 44 00

Safety never hurts! Always read the Operator's Manual before working with any equipment. Inspect equipment before using it, and be sure it is operating properly. Follow the product safety signs, and use any safety features provided. This literature has been published for worldwide circulation. The standard and optional equipment and the availability of individual models may vary from one country to the next. Case IH reserves the right to undertake modifications without prior notice to the design and technical equipment at all times without this resulting in any obligation whatsoever to make such modifications to units already sold. Whilst every effort is made to ensure that the specifications, descriptions and illustrations in this brochure are correct at the time of going to press, these are also subject to change without prior notice. Illustrations may show optional equipment or may not show all standard equipment. Case IH recommends **AKCELA** lubricants.

Printed in Italy - Cod.No. 24MEAC0001COMINB

